

7.1 OVERVIEW

7.2 CITY & REGIONAL ROADWAY IMPROVEMENTS

7.3 PARKING

7.4 TRANSIT

7.5 PEDESTRIAN & BICYCLE CIRCULATION

7.6 TRUCK ACCESS

7.7 STREET CROSS SECTIONS

- WILLOW STREET
- ENTERPRISE DR. - WEST
- CENTRAL AVE.
- TRANSIT STATION ENTRANCE ROAD
- ENTERPRISE DRIVE - EAST
- HICKORY STREET
- NEIGHBORHOOD STREETS
- CARRIAGEWAYS
- ROUNDBOUTS
- TRAFFIC CIRCLES
- CUL DE SACS - HAMMERHEADS
- CUL DE SACS - TRADITIONAL

7.8 STREET STANDARDS CHART

7.0 CIRCULATION

7.1 OVERVIEW

The Specific Plan provides a hierarchy of streets, walkways and pedestrian links throughout the Plan area. Streetscape design and street layouts organize the community and slow the traffic. A block pattern will disperse traffic and create local streets that are pleasant to live on and walk or bike along. This street pattern, with its various pedestrian connections, will provide a seamless network of connectivity for pedestrians throughout the Plan area. By providing street trees in the parkways, removing many of the driveway curb cuts, and incorporating traffic calming measures such as narrowing at intersections and roundabouts, the street design encourages walking and biking through the community and to the outlying region.

The streets within the Plan area have been designed as “Complete Streets.” Complete Streets are designed and operated to enable safe access for all users. Pedestrians, bicyclists, and motorists of all ages and abilities are able to

safely move along and across a Complete Street. Complete Streets play an important role in livable communities, where all people – regardless of age, ability or mode of transportation – feel safe and welcome on the roadways. A safe walking and bicycling environment is an essential part of creating friendly, walkable, healthier and more sustainable communities. In order to create a network of pedestrian and bicycle friendly streets, the Specific Plan establishes street design standards for the Specific Plan area.

The Backbone Circulation Plan (Exhibit 7.2) and Street Standards Table (Table 7.1) near the end of this chapter, illustrate the locations of the various street classifications provided for in this Specific Plan. Residential street alignments are approximated based on the optimal street network to maximize walkability. Final street layouts shall be determined at time of final maps.

7.2 CITY & REGIONAL ROADWAY IMPROVEMENTS

There are several ongoing and proposed regional improvements in Alameda County that are intended to address existing and future traffic congestion within or near the City of Newark and which are illustrated on Exhibit 7.1 - Regional Circulation Improvements.

Regional Improvements Outside the Planning Area (including Regional Transit Improvements)

- Per the Alameda County Transportation Commission (Alameda CTC), improvements are planned to the Regional Express Bus Improvements (SR 84 Lane Expansion/HOV, Ardenwood Express Bus Park).
- Altamont Commuter Express Rail.
- Dumbarton Rail Project.

No other improvements to increase transit capacity are identified by the Alameda CTC.

The above improvements are part of the Congestion Management Program administered by the Alameda CTC. If applicable, these improvements would be funded in part by the payment of regional transportation impact fees from applicants of Specific Plan uses as specific development proposals are brought forth.

City Road Improvements Outside the Planning Area

While not a requirement of the Specific Plan project, per the City of Newark's General Plan Circulation Element (1989, updated 2007), the following improvements are planned for the City:

- Roadway Improvements:

- Widen Thornton Avenue, from SR 84/ Dumbarton Freeway to Jarvis Avenue and from Jarvis Avenue to the Union Pacific railroad tracks.
- Complete the Cedar Boulevard extension from Haley Street to Thornton Avenue (including railroad underpass).
- Construct railroad overpass at Union Pacific railroad tracks on Central Avenue.
- Widen and improve Mowry Avenue from Cherry Street to the Union Pacific railroad tracks (including a railroad overpass).
- Widen the Central Avenue overpass of I-880/ Nimitz Freeway.

-Intersection Improvements:

- Cherry/Mowry: Re-stripe westbound for shared through and dual left turn; Construct northbound free right; Widen Mowry for eastbound/westbound dual left and two through lanes.
- Mowry/Cedar: Widen Mowry for eastbound dual left.
- Mowry/New Park: Re-stripe southbound for exclusive left-turn lane; Install northbound right-turn arrow; Widen northbound for exclusive left-turn lane, re-stripe for dual right-turn shared with through lane.
- Thornton/Cedar: Lengthen northbound right-turn lane with right-turn overlap.
- Cherry/Central: Widen Cherry for northbound dual left-turn.

Specific Plan Circulation Improvements

The Backbone Circulation Plan for the Specific Plan is shown in Exhibit 7.2.

The Specific Plan will need a connected internal street network with connections to the greater City of Newark. In addition to the street network itself, streetscape design will play an important role in transforming the Plan area into a livable community. As the most pervasive, visual and physical component of the public realm, the design of the street network is an integral part of the image and experience of the area. This chapter details what the street experience will feel like, the street design typologies and character to guide future projects.

The following are General Plan Policies applicable to general circulation policies in the Specific Plan.

Street Network Policy Goals

Street Network Design

C-1 Create a street network that connects with existing local and regional roadways, such as Enterprise Drive, Willow Street, and Central Avenue, and provides for efficient and safe circulation throughout the Plan area. Speed limit shall be 25 miles per hour throughout the development.

C-2 Create a street network that is appropriate for a mixed-use, pedestrian-oriented environment that extends to the Transit Station area. This network should establish:

- Blocks that are pedestrian in size, i.e. blocks that around 450-feet have a more pedestrian scale than

blocks that are larger, except along major arterials;

- Mid-block pedestrian connections where appropriate, i.e. blocks that are larger than 450-feet should have pedestrian paths to break up the walking plane, except along major arterials; and,
- Where mid-block pedestrian crossings are needed, mid-block crosswalks should be provided per the City's "Bicycle and Pedestrian Master Plan/ Crosswalk Guidelines" (upcoming, 2010-2011).

C-3 Medians should occur on streets which comprise the Backbone Circulation Plan where provided in Chapter 7. All streets should be designed with sidewalks buffered from vehicle traffic by a landscape strip, landscaping, travel lanes, bike lanes, and parking, where appropriate.

C-4 Streets should meet the needs of all users including drivers, bicyclists, pedestrians, persons with disabilities, and transit users.

C-5 Street improvements should be built consistent with the street design standards in this chapter.

C-6 Traffic into existing residential communities should be minimized to the greatest extent possible.

C-7 Culs-de-sac should be minimized to the greatest extent possible.

C-8 The use of permeable paving for parking isles, parking lots, and vehicular entries to residential areas should be used

 ENTERPRISE DR. WEST, HICKORY ST., CENTRAL AVE.

 EXISTING ENTERPRISE DR. EAST

 TRANSIT STATION ENTRANCE

 IMPROVED WILLOW STREET

 POTENTIAL NEIGHBORHOOD STREETS

* THERE WILL BE ADDITIONAL RESIDENTIAL STREETS THROUGHOUT THE PLAN AREA AS PER THE TENTATIVE MAP APPROVALS

** NEIGHBORHOOD STREETS ARE NOT PART OF THE BACKBONE CIRCULATION PLAN. THE DESIGN OF NEIGHBORHOOD STREETS SHALL BE AS PROVIDED IN THIS SPECIFIC PLAN, BUT THE LOCATION OF EACH WILL BE DETERMINED PURSUANT TO THE PROCESSING OF PLANS FOR SPECIFIC DEVELOPMENTS WITHIN THE SPECIFIC PLAN AREA.

 ROUNDABOUTS

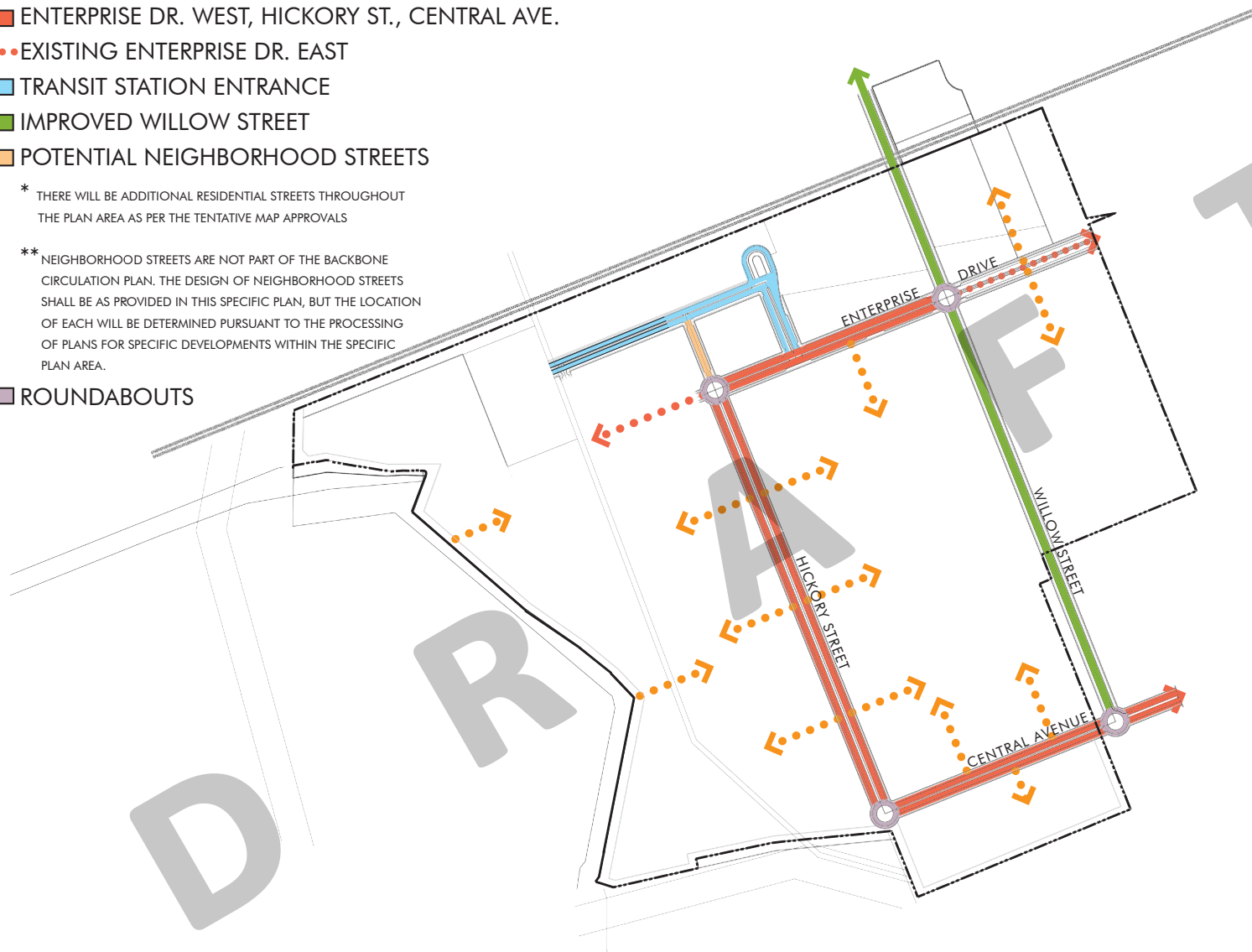

Exhibit 7.2 - Backbone Circulation Plan

in the greatest extent possible.

C-9 Where applicable, applications for projects shall indicate how streets are connected to existing local and regional roadways, and , if adjacent to the Station Area, how they are connected to the Station Area street network.

C-10 Arterials and collectors should generally be located as shown in Exhibit 7.2 – Backbone Circulation Plan. Exact locations of arterials and collectors may be modified based upon additional engineering. Streets shall be located consistent with the following criteria:

- Enterprise Drive, Hickory Street, Willow Street and Central Avenue are to be located generally as shown on Exhibit 7.2; and,
- Street alignments may vary to accommodate site conditions and specific project needs.

C-11 A street shall connect directly from Enterprise Drive to the Transit Station. This street shall be consistent with the street standard in this chapter for the “Transit Station Entrance Road.”

C-12 Enterprise Drive, Hickory Street, Central Avenue, Willow Street, neighborhood streets and carriageways shall be constructed according to the design standards set forth in this chapter.

Transportation Demand Management

C-13 Provide for a Transportation Demand Management (TDM) program that aims to reduce single-occupant vehicular

trips. Components of a TDM program may include:

– Urban Design Projects:

- Short and long-term bicycle parking in highly visible, well lit locations that are convenient to front building entrances; and,
- Direct routes to the Transit Station and other key destinations that are well lit and designed for pedestrian comfort.

– Additional Concepts:

- Free or preferential parking designed for carpool, van pool, low emission vehicles, and car share vehicles; and,
- Passenger loading zones and/or kiss-n-ride areas, and Bicycle and pedestrian friendly site planning and building design.

Employer Based TDM is not large enough and will not have enough employers to implement and manage an employer TDM.

Construction Traffic Management

C-14: Development proposals shall contain the following at a minimum:

- A set of comprehensive traffic control measures, including limiting major truck trip and deliveries that avoid peak traffic hours, detour plans, if required, lane closure procedures, sidewalk closure procedures, signs, cones for drivers, and designated

construction access routes;

- Notification procedures for adjacent property owners and public safety personnel regarding when major deliveries, detours and lane closures will occur;
- Notification of construction staging areas for materials, equipment, and vehicles (must be located on the project site);
- Identification of haul routes for movement of construction vehicles that minimize impacts on vehicular, bike, or pedestrian traffic, circulation, and safety;
- Temporary construction fences to contain debris and material, and to secure the site;
- Provisions for removal of trash generated by project construction activity;
- A process for responding to, and tracking, complaints pertaining to construction activity, including identification of an on-site complaint manager; and,
- Provisions for monitoring surface streets for truck routes so that any damage and debris attributable to the tracks can be identified and corrected.

7.3 SPECIFIC PLAN PARKING

Transit Oriented Developments require substantial amounts of parking near transit to make them feasible and to accommodate passengers as not everyone will walk to the Transit Station. Therefore, parking becomes one of the most critical land use elements of a TOD. If too much parking is provided, the benefits of reducing traffic and congestion

with a TOD are negated. If not enough parking is provided, the TOD may suffer as people struggle to find places to park. Parking is also very expensive to build, especially structured parking, and can be an incentive as well as a deterrent for certain types of development.

National studies show that within transit oriented developments, some reductions in off-street parking can be appropriate. The factors influencing reduced parking ratios are primarily based upon (1) the mix of complimentary uses; (2) the availability of pedestrian, bicycle, transit and other non-motorized modes of travel; and (3) the availability of smaller unit sizes near the Transit Station. These factors can also be combined with other parking reduction techniques, such as “shared-use” parking which can reduce the overall amount of parking needed for a development. Reducing parking directly affects cost and saves valuable land.

With mixed-use and residential areas close to the Transit Station (Exhibit 7.3), and the proximity of the Transit Station to adjacent retail and commercial uses, many opportunities to reduce the amount of parking by shared parking arrangements are available. Factors such as: final Transit Station design and access, surrounding land uses, and cooperation between property owners will determine the final parking strategy. These factors will lead the decision on shared parking arrangements, and the phasing and implementation of projects. Parking studies might be needed where a project proposes a shared parking arrangement and/or to reduce or increase the amount of parking otherwise required for the Specific Plan area. These studies will be reviewed by the

Community Development Director for the City of Newark. Exhibit 7.4 - Station Parking Potential and Station Circulation illustrates a possible scenario addressing parking needs for the station area.

The Transit Station is expected to serve potential riders beyond residents of the proposed Plan area. To provide regional access to the Station, providing adequate vehicle parking is needed to encourage ridership and provide connections to the regional and citywide transportation networks. Parking design and placement is another critical element to TOD's success. It can strongly affect how drivers accessing that station use the amenities on site.

Parking Policies

Parking Location

C-15: Within the Transit Station area, locate parking behind buildings, to the maximum extent feasible.

General Parking Standards & Guidelines

C-16 Maintain flexible parking standards that balance the need for parking with the broader Transit Station goals of encouraging transit ridership, ridesharing, and enhancing the area's pedestrian appeal.

C-17 Include on-street parking on most streets, consistent with the detailed street design standards in this chapter.

C-18 Adopt parking standards for the Plan area. Consider some or all of the following strategies to prevent oversupply and to encourage the use of alternate modes of

transportation:

- Allow shared parking between the various uses with different peak periods of parking demand;
- Reduce minimum off-street parking requirements for multi-family and commercial developments;
- Adopt maximum off-street parking requirements;
- Allow credits for availability of adjacent on-street spaces;
- Allow exemptions for small retail and dining establishments (e.g. less than 2,500 square feet) in pedestrian centers;
- Tandem parking can be utilized for up to 25% of the units in a given area; and,
- Allow permeable pavement use in overflow parking lots.

C-19 Work with property owners to encourage adoption of shared parking arrangements where appropriate to maximize efficient use of parking resources.

C-20 Incentivize parking structures, rooftop parking, and underground parking through flexibility in conditions of approval and in opportunities for any City, State or Federal financial participation in the development.

C-21 Work with the Transit Station operator to identify phasing of parking fields for a total of 500 spaces at full build out of the Station.

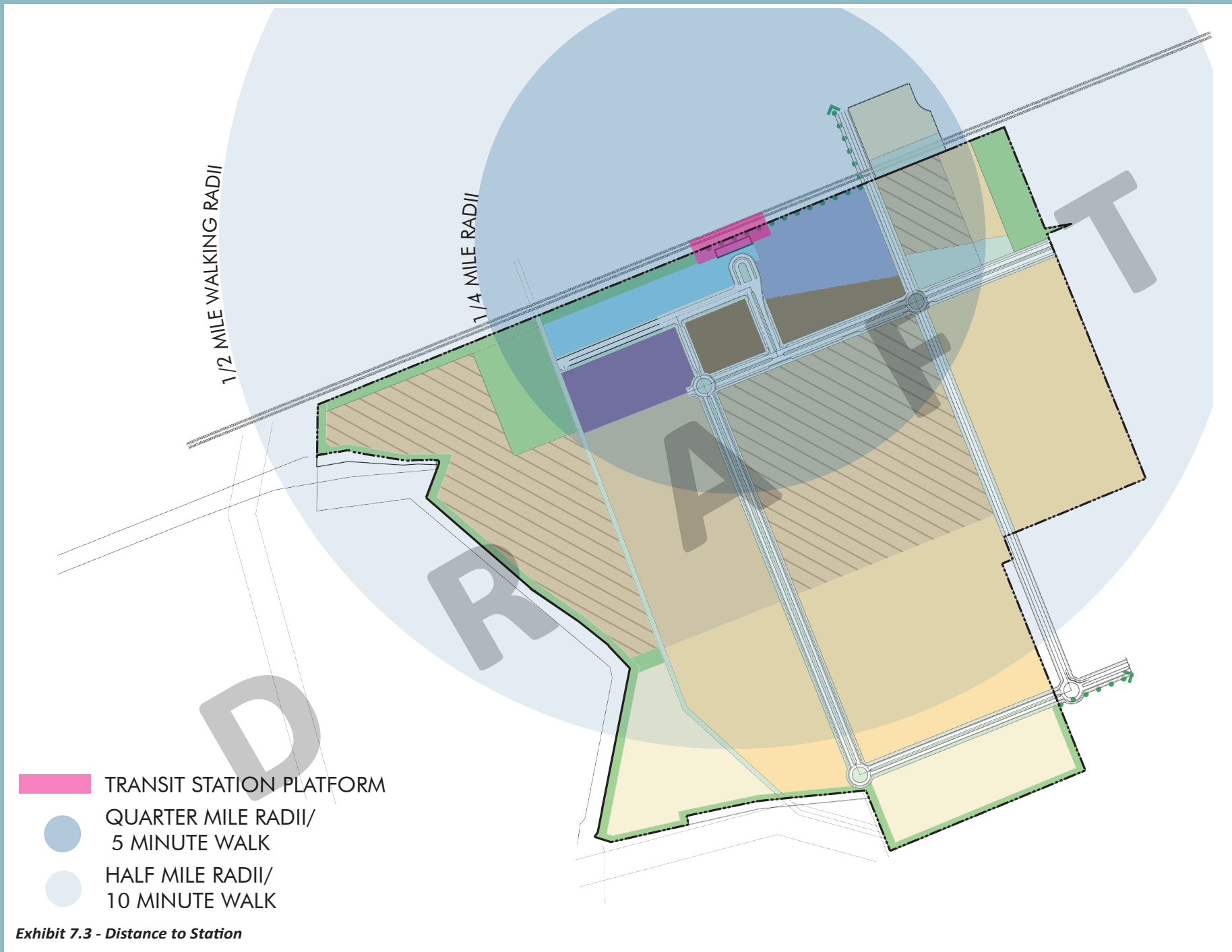

Exhibit 7.3 - Distance to Station

7.4 TRANSIT

The Dumbarton Rail Line runs parallel to the Dumbarton Bridge and connects the eastern side of the Bay to the Peninsula. Because the rail line is already in place and rights-of-way are intact, the most feasible Transit Station to serve the City of Newark is within the Specific Plan area along the rail line as depicted in Exhibit 7.3. This is both an advantage and a disadvantage for planning purposes. With the rail line already in place, it eliminates the costs associated with acquiring rights-of-way, but limits where the station can be placed. However, the Specific Plan has been designed to take advantage of the Transit Station's location by placing a large number of new residential units in the Specific Plan area within a 1/2-mile (10 minute) walking distance from the station as shown in Exhibit 7.3.

In addition, regional bus service may be established at this location to further enhance the TOD experience of the neighborhood. For this reason, a bus station hub will be included in the overall planning of the Station.

The following policies are recommended to enhance transit opportunities throughout the Plan area and maximize their use by Plan area residents, and visitors.

Transit Policies

C-22 The City shall continue working with the regional transit agencies to study design, funding and construction options for the Transit Station. The design and location should achieve the following goals:

- Provide direct pedestrian and bicycle route from Enterprise;
- Encourage a shared parking agreement between the Station and the future adjacent uses to minimize the amount of overall parking in the Plan area;
- Maximize developable land within the Plan area; and,
- Provide direct line of sight from Transit Station to Enterprise Drive/Willow Street.

C-23 Develop a Transit Station that provides access to the various modes of transit. Design the Station to include:

- Bus pick-up and drop-off bays;
- An area for limited short-term waiting;
- Disabled parking areas;
- Shuttle pick-up and drop-off areas; and,
- Safe and attractive pedestrian and bicycle crossings to and from the Station.

C-24 Where necessary, design streets to accommodate transit services, including bus stops and shelters (Table 7.1).

- 1/4 MILE RADII : 5 MIN WALK
- TRANSIT STATION
- BIKE PATHS
- BUS ROUTES
- PEDESTRIAN ACCESS
- TRANSIT STATION PARKING
- RETAIL PARKING
- COMMERCIAL PARKING

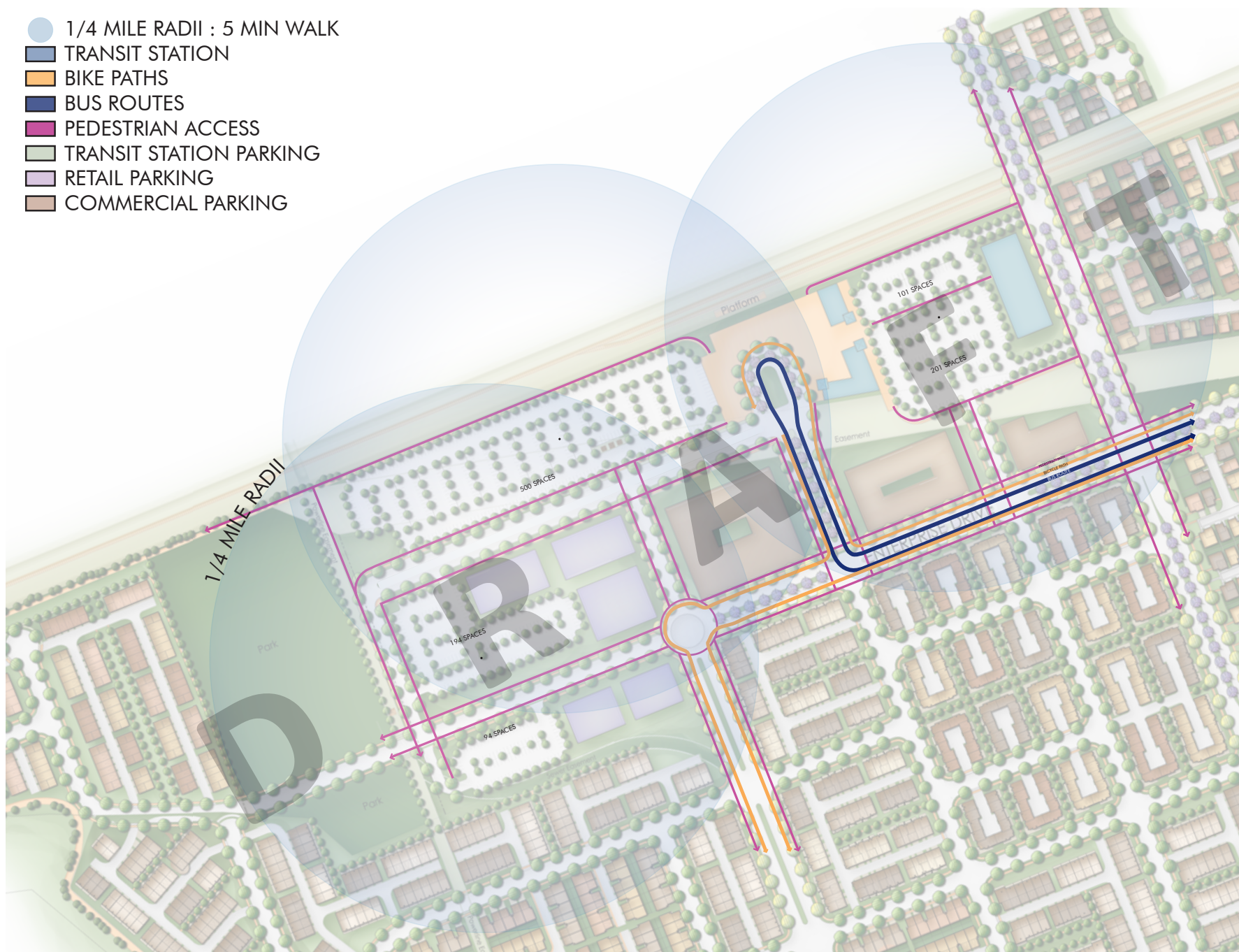

Exhibit 7.4 - Transit Station Parking Potential & Station Circulation Plan

7.5 PEDESTRIAN & BICYCLE CIRCULATION

The goal of the Specific Plan is to create attractive, safe, inviting and efficient pedestrian and bicycle circulations throughout the Plan area. These connections form an important link for residents, and visitors to the Plan area.

The primary backbone of the pedestrian and bicycle networks will be the internal street network of the community. Designated bicycle lanes will be provided on key internal roadways.

Under the Plan, all new streets shall have sidewalks or other adjacent pedestrian facilities as illustrated in the street cross-sections described in greater detail later in this chapter. The Specific Plan policies seek to ensure that pedestrian and bicycle networks are linked to the Transit Station to the greater City of Newark and to the neighboring communities.

Exhibit 7.5 – Pedestrian and Bicycle Circulation shows key bicycle routes that should be established and maintained. Exhibit 7.6 illustrates Class I, Class II and Class III bicycle paths.

Pedestrian & Bicycle Circulation Policies

C-25 Prioritize pedestrian and bicycle safety at intersections and street crossings of Backbone streets with measures such as:

- Contrasting and/or textured paving crosswalks; and
- In-ground, blinking crosswalk lights where feasible.

C-26 Incorporate signage to indicate pedestrian and bicycle areas where feasible.

C-27 Projects should provide access to direct pedestrian and bicycle routes to the Transit Station as feasible and where appropriate.

C-28 Adopt minimum bicycle parking requirements for residential and commercial projects.

C-29 In the Transit Station Area, design streets and sidewalks consistent with this chapter, including:

- Tree wells or planter strips with trees between the sidewalk and the parking areas;
- Pedestrian scale street lights;
- Limited curb cuts that cross the pedestrian path of travel;
- Outdoor seating for restaurants and cafes where applicable;
- Projections into the right-of-way for awnings, canopies, pedestrian oriented signs, bay windows, and other elements that enhance the pedestrian realm; and,
- Sidewalks should have a minimum five-foot wide path of travel.

C-30 Mid-block crosswalks should be provided per the City's Bicycle and Pedestrian Master Plan/Crosswalk Guidelines (upcoming, 2010-2011).

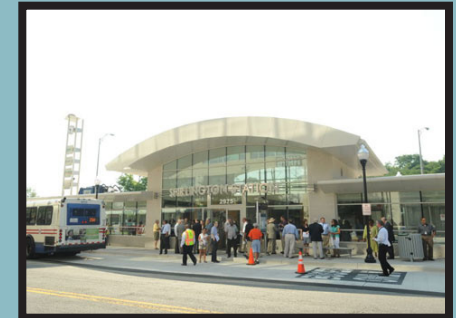
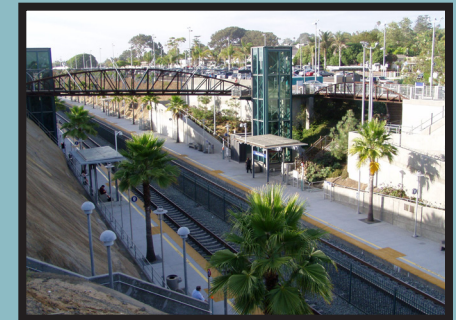



Pedestrian and Bicycle Circulation Improvements

C-31 Provide bicycle routes throughout the Transit Station area, as illustrated in Exhibit 7.4.

C-32 Allow bicycle circulation on all local streets in the greatest extent feasible.

C-33 Design and implement a trail interior to the Plan area, around the perimeter of the Specific Plan, as feasible.

C-34 To the greatest extent possible, link internal neighborhood to parks and public spaces.



7.6 TRUCK ACCESS







Because of the transit-oriented nature of the Specific Plan, truck routes and loading areas should be carefully considered. Access to garbage and recycling areas should also be considered early in the project design process. Access should be provided in a way that facilitates truck service without detracting from the pedestrian realm.

Truck Access Policies

C-35 Where truck routes are necessary, do not locate them in areas where there are no commercial establishments.

C-36 Service and loading areas should be strategically located and screened so as not to impact the attractiveness and safety of the pedestrian realm. Therefore, they should be located to the side or rear of buildings, away from pedestrian area.

C-37 Loading requirements for smaller businesses may be met through curbside loading zones. For larger developments that required loading docks, the docks should be located in the interior or rear of the building or parking garage, to the greatest extent feasible.

-  CLASS I SEPARATED BIKEWAY PATHS
-  CLASS II BIKE LANES
-  CLASS III BIKE ROUTES
-  POTENTIAL BICYCLE PARKING
-  TRAIL
-  PEDESTRIAN CIRCULATION
-  POTENTIAL NEIGHBORHOOD STREETS

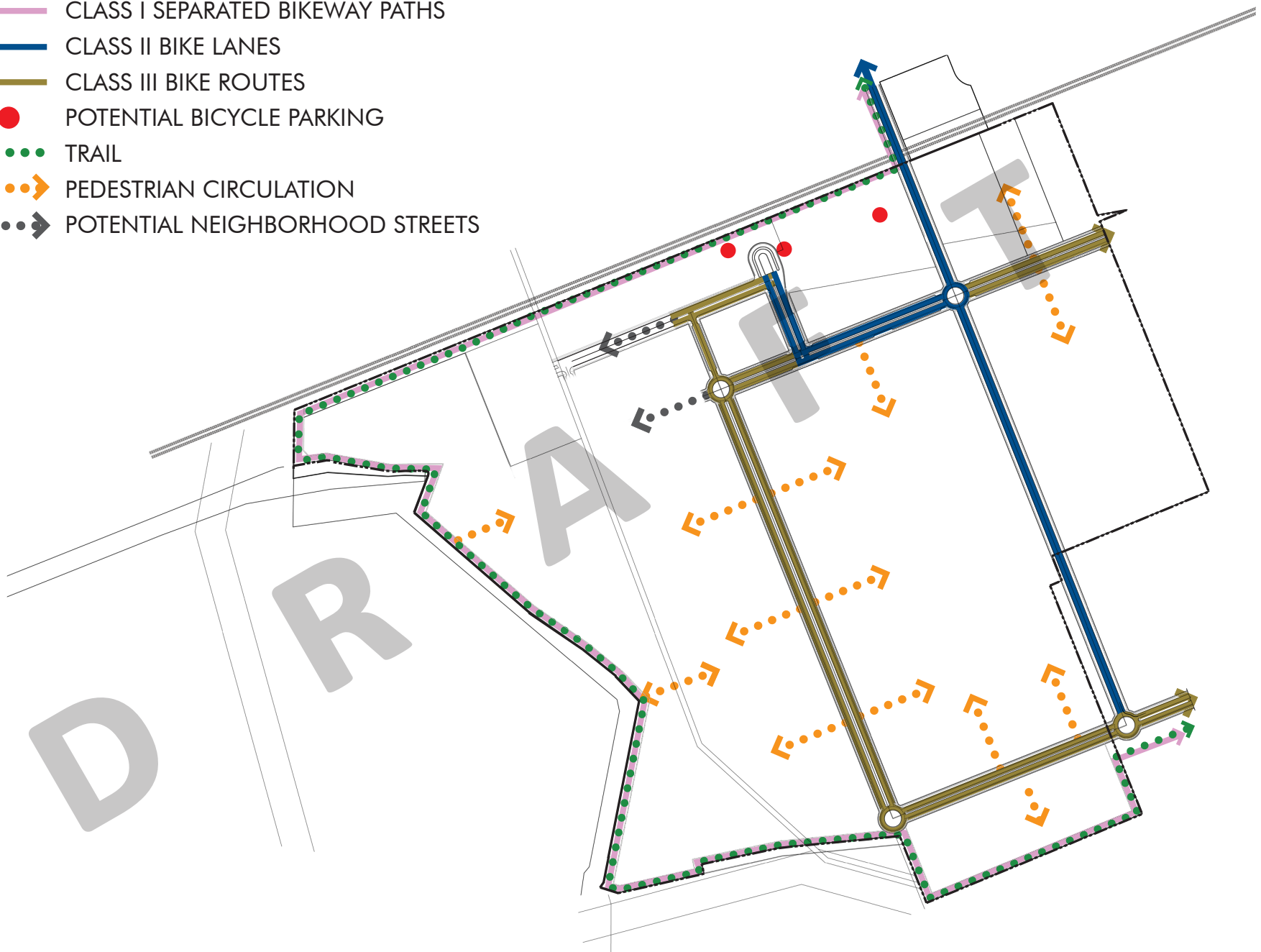
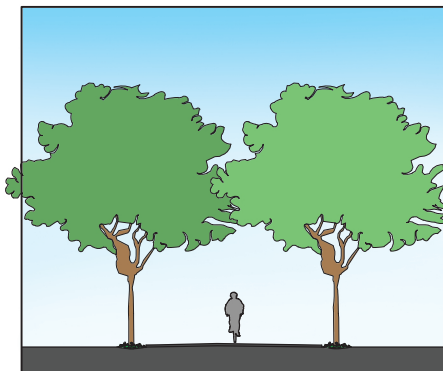
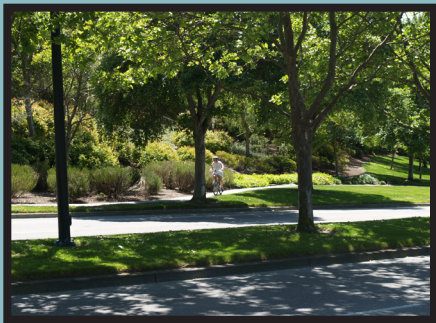
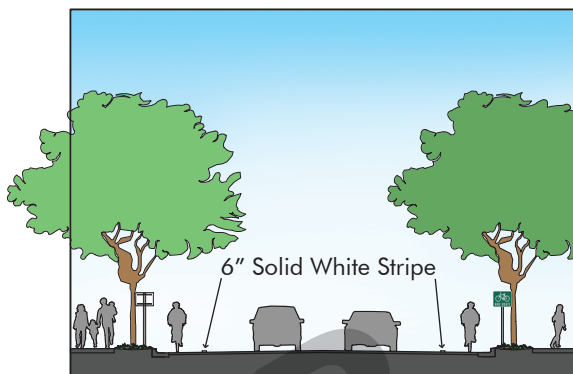
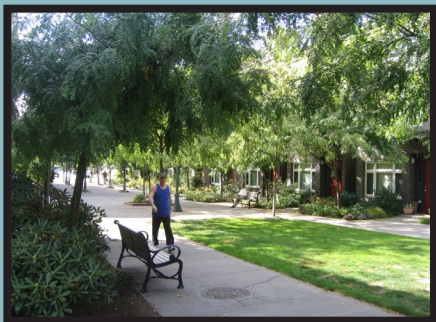

Exhibit 7.5 - Pedestrian & Bicycle Circulation



CLASS I BIKEWAY (Bike Path)

Provides a completely separated right-of-way for the exclusive use of bicycles and pedestrians with crossflow minimized.



CLASS II BIKEWAY (Bike Lane)

Provides a striped lane for one-way bike travel on a street or highway.

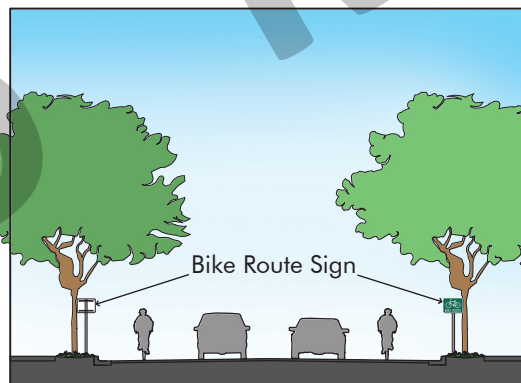

CLASS III BIKEWAY (Bike Route)

Provides for shared use with pedestrian or motor vehicle traffic.



Exhibit 7.6 - Bicycle Paths

7.7 STREET CROSS SECTIONS

One of the most visible character-defining elements of a community are the streets; people use them on a daily basis to conduct the business of their lives. This section illustrates the design intent of the street network for the Specific Plan. Each exhibit shows the entire right-of-way required, street dimensions, sidewalks, and landscape strip. The number of travel lanes on all streets have been designed to accommodate the ultimate build-out of the Specific Plan through the use of street cross section graphics. All projects and subdivisions should be consistent with the Plan. Minor modifications are anticipated and final design will be made during the mapping process.

Although the following street cross-sections incorporate portions of the current City of Newark standards, these new street cross-sections are more specific than the City's general standards as they address the overall character of each street.

The following pages detail each street section.





Willow Street (Exhibit 7.7 (a), (b), and (c))

This street's primary purpose is to move and disperse traffic into the Plan area. These are higher volume streets with a design speed of 35 miles per hour. Traffic calming measures such as roundabouts, chicanes, pavers, etc., are required at every intersection within the Plan Area along this roadway.

Existing Willow street consists of a 64-foot wide paved road section within an 80-88-foot wide right-of-way. The proposed Willow Street section consists of two 15-foot vehicular travel lanes, two 5-foot bicycle lanes, and two 8-foot parking bays on either side of a median.

The roadway has a vertical curb and gutter, and curb returns have a 20-foot radius.

A 5-foot sidewalk is provided along with a 3-8-foot wide landscape strip. Direct lot access from single-family lots is not allowed along Willow Street however, curb cuts and all means of ingress and egress are allowed along Willow Street for all other uses.

Landscaping along Willow Street should include continuous street tree planting. Consistent street trees should be utilized in order to provide continuity and orientation along this collector road. Trees should be planted at even intervals and selected for characteristics that include proven durability in street environments, branching at heights greater than 15-feet, and ease of maintenance. The landscaped strip should be planted with a combination of shrubs and groundcovers.



Enterprise Drive West (Exhibit 7.8 (a) and (b))

The primary purpose of these streets is to move and disperse traffic into the Plan area. These are higher volume streets with a design speed of 35 miles per hour. On Enterprise Drive West, specifically between Willow Street and Hickory Street, direct lot access for single-family detached homes is not allowed however, curb cuts and all means of ingress and egress are allowed for all other land uses.

Enterprise Drive West consists of a 90-foot wide right-of-way. This is intended to be a divided road with a median in the center that can accommodate trees and landscaping. The paved sections of Enterprise, from Willow to the Transit Station entrance, consists of two 12-foot vehicular travel lanes on either side of the median. The roadway has a vertical curb and gutter.

A 5-foot sidewalk is provided on both sides and separated from the roadway by a 6-foot wide landscape strip.

The sidewalks located along Enterprise Drive West are planned to be 5-feet in width, however, when located adjacent to commercial or retail uses, it is encouraged that the sidewalk width be a minimum of 8-feet and a maximum of 16-feet. This will ensure adequate space for outdoor activities, such as cafe style restaurant seating and an increased pedestrian traffic.

Enterprise Drive West serves as the main entry into the site and should have distinctive landscaping.

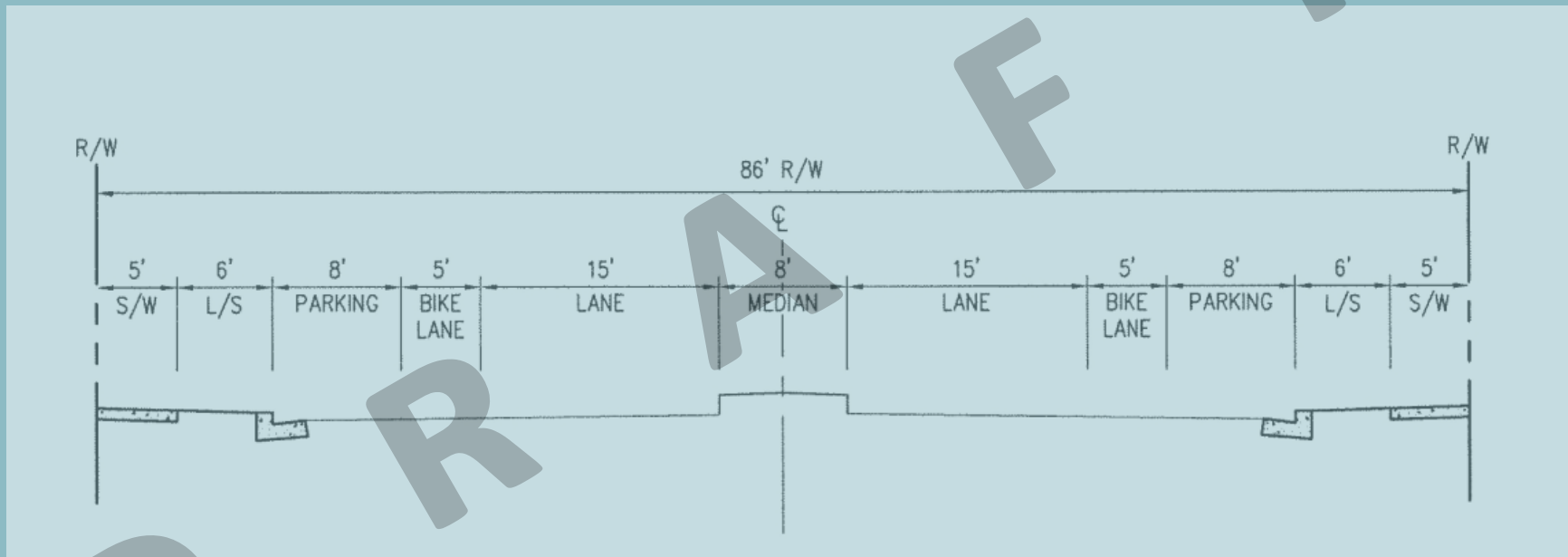

Exhibit 7.7 (a) - Willow Street (North of Enterprise Drive)

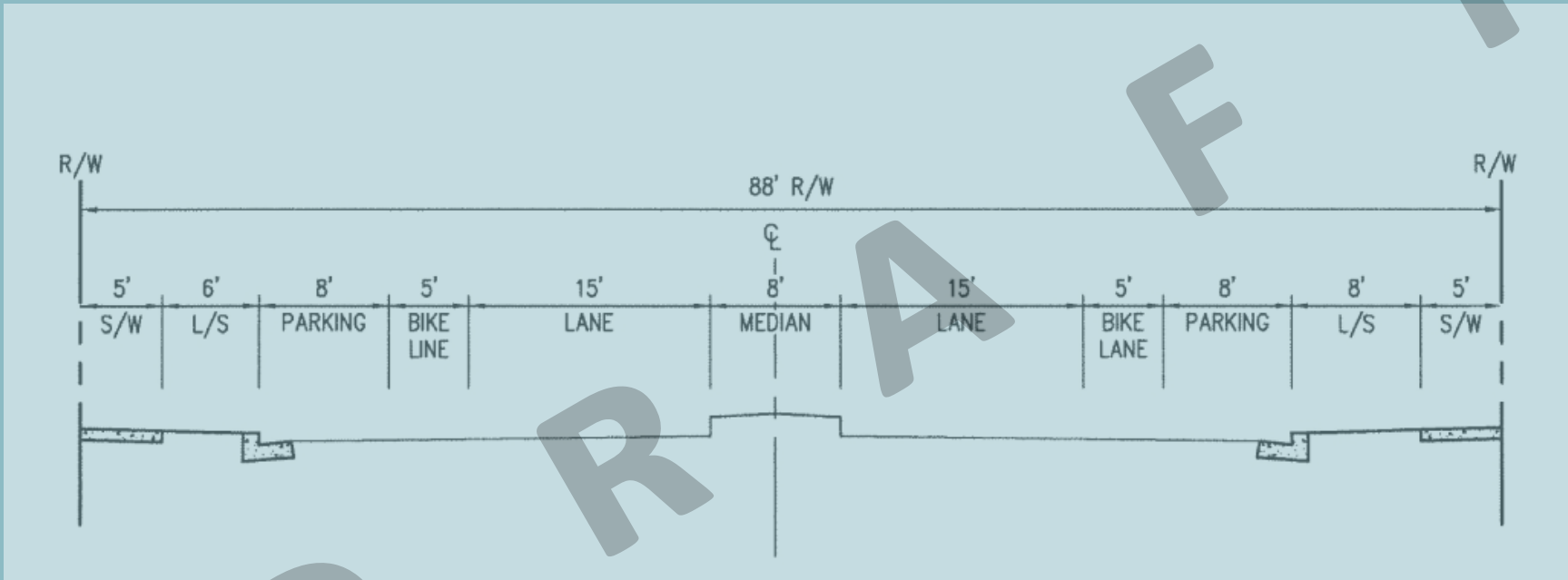

Exhibit 7.7 (b) - Willow Street (North of F-6 Ditch)

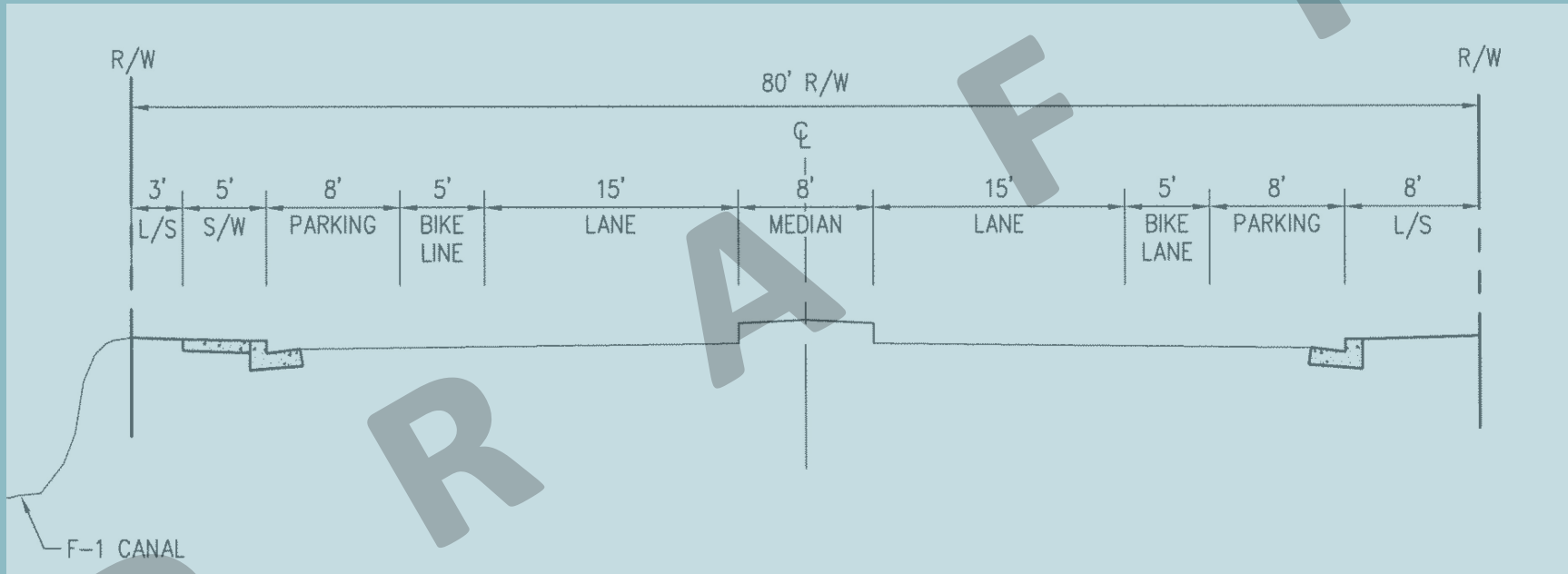

Exhibit 7.7 (c) - Willow Street (South of F-6 Ditch)

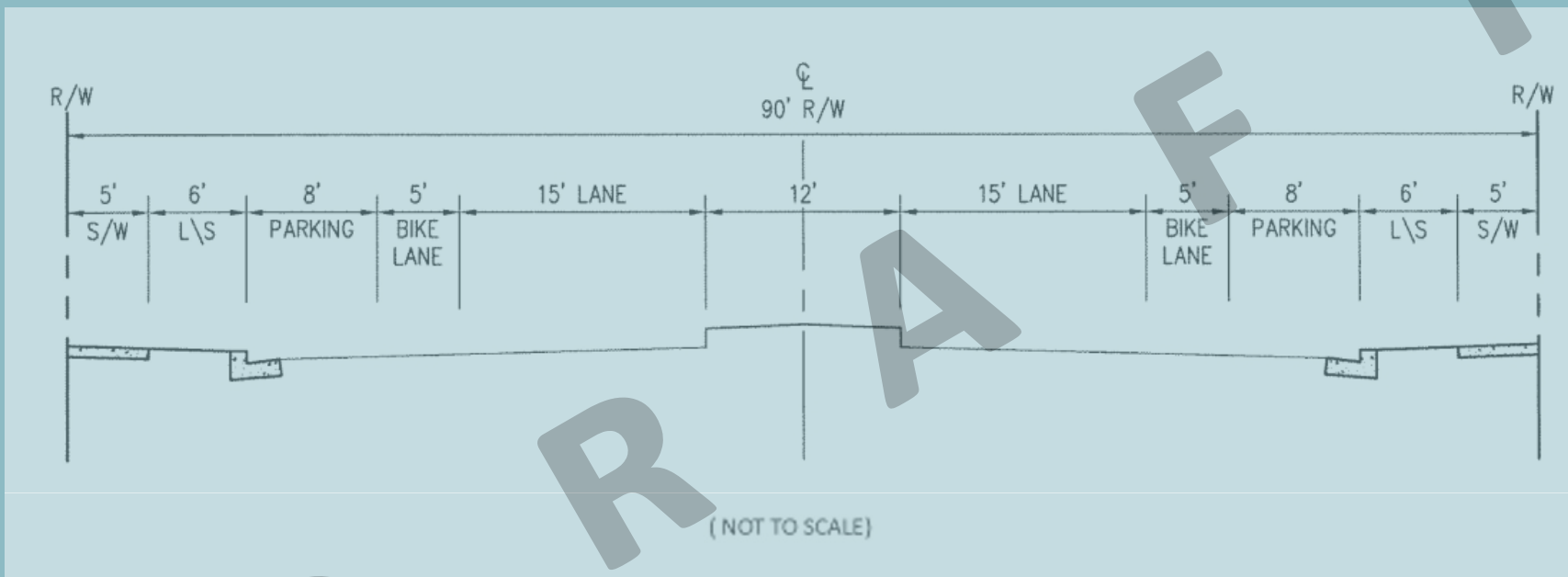

Exhibit 7.8 (a) - Enterprise Drive West (West of Transit Station Entrance)

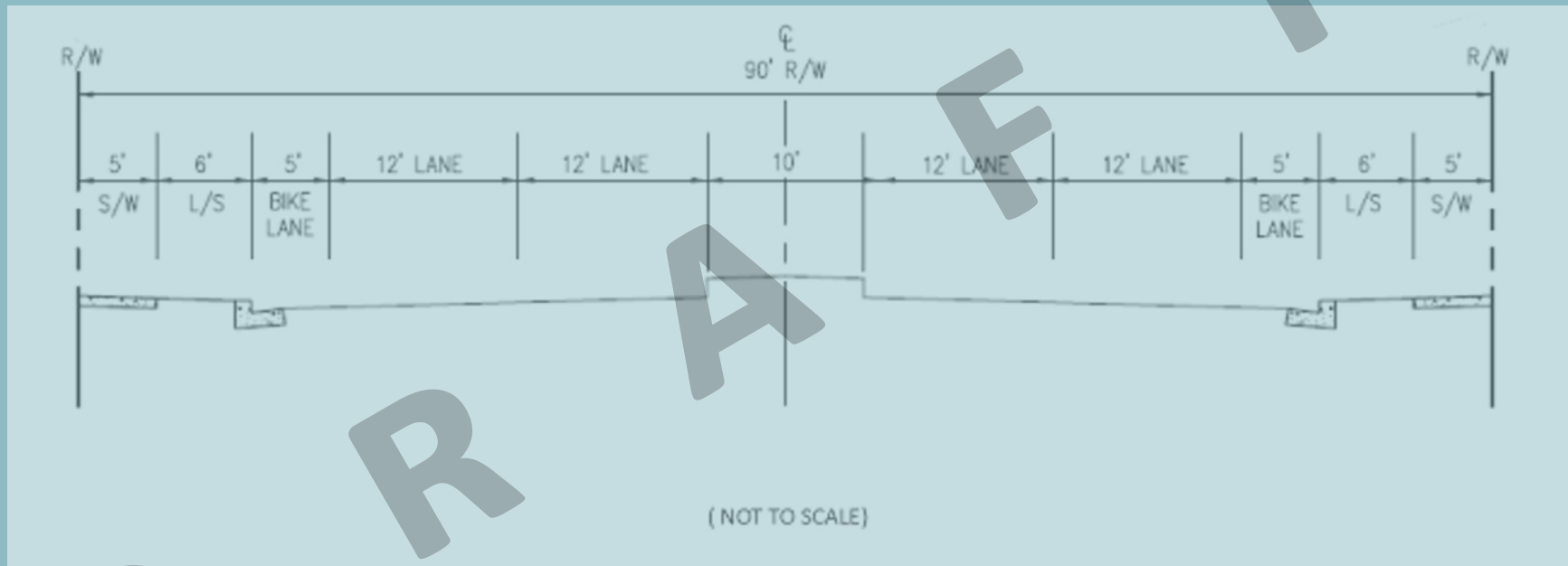

Exhibit 7.8 (b) - Enterprise Drive West (Transit Station Entrance to Willow Street)

Central Avenue (Exhibit 7.9)

The street consists of a 40-foot paved road within an 60-foot wide right-of-way. The paved section of the right-of-way consists of two 12-foot vehicular travel lanes, and 8-foot parking bays. The roadway has a vertical curb and gutter, and curb returns at a 20-foot radius. Direct lot access is permitted on Central Avenue from residential lots to the street. A 5-foot sidewalk is provided on both sides and separated from the parking areas and roadway by a 5-foot wide landscape strip.

Transit Station Entrance Road and Transit Station Road (Exhibits 7.10 (a) and (b))

The street that leads to the Transit Station from Enterprise Drive needs to be distinctive to give this area a sense of place and to draw people to transit and retail opportunities. This street's purpose is to provide access to the station for cars and buses, plus access to parking and drop-off, and to allow bicycle and pedestrian access to the station. This is a higher volume street with a lower design speed of 25 miles per hour, for safety.

The Transit Station Entrance Road consists of a 90-foot wide right-of-way. This is a divided road with a 10-foot median in the center that can accommodate trees and landscaping. The paved section of the right-of-way consists of four 12-foot vehicular travel lanes, and two 5-foot bicycle lanes as depicted in Exhibit 7.10(a). The roadway has a vertical curb and gutter, and curb returns have a 20-foot radius. The Transit Station Road runs perpendicular to the Transit Station Entrance run as set forth in Figure 7.2 and consists

of an 80-foot right-of-way, two 12-foot vehicular travel lanes, two 5-foot bicycle lanes, an 8-foot parking bay on either side and a 14-foot median as depicted in Exhibit 7.10(b). Direct lot access is permitted on the Transit Station Entrance Road and the Transit Station Road. Two 5-foot sidewalks are provided on both sides and separated from the roadway by two 6-foot wide landscape strips for both the Transit Station Entrance Road and Transit Station Road.

To help accentuate the Station, strong simple vertical massing of trees along with low-growing evergreen shrubs and grasses are encouraged. Flowering ground cover and accent trees at corners and intersection should delineate entrances. Visibility of the Transit Station is imperative so trees with branching at heights greater than 15-feet should be utilized. Where adjacent parking lots are planned, a planting screen should be designed through the use of shrubbery, landscape berming, low walls, or a combination of these elements.

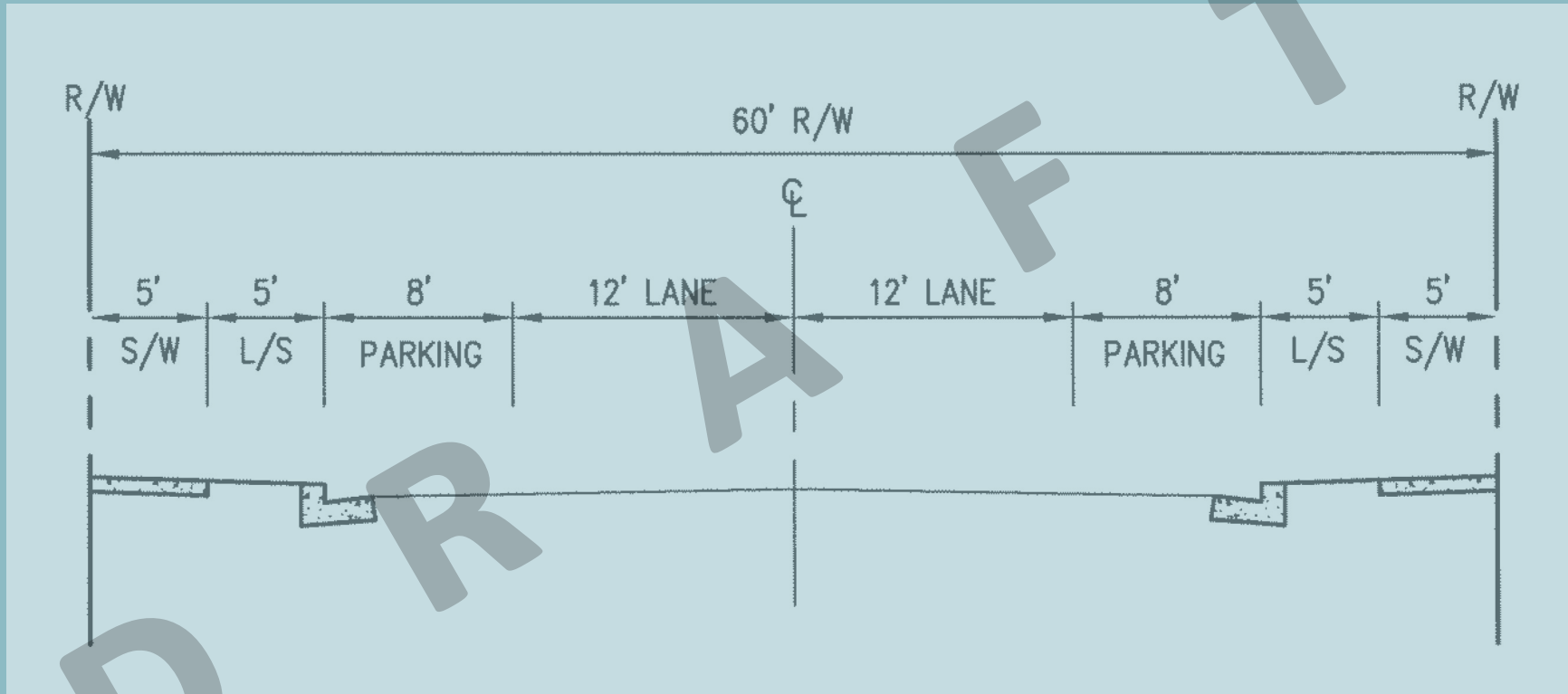

Exhibit 7.9 - Central Avenue

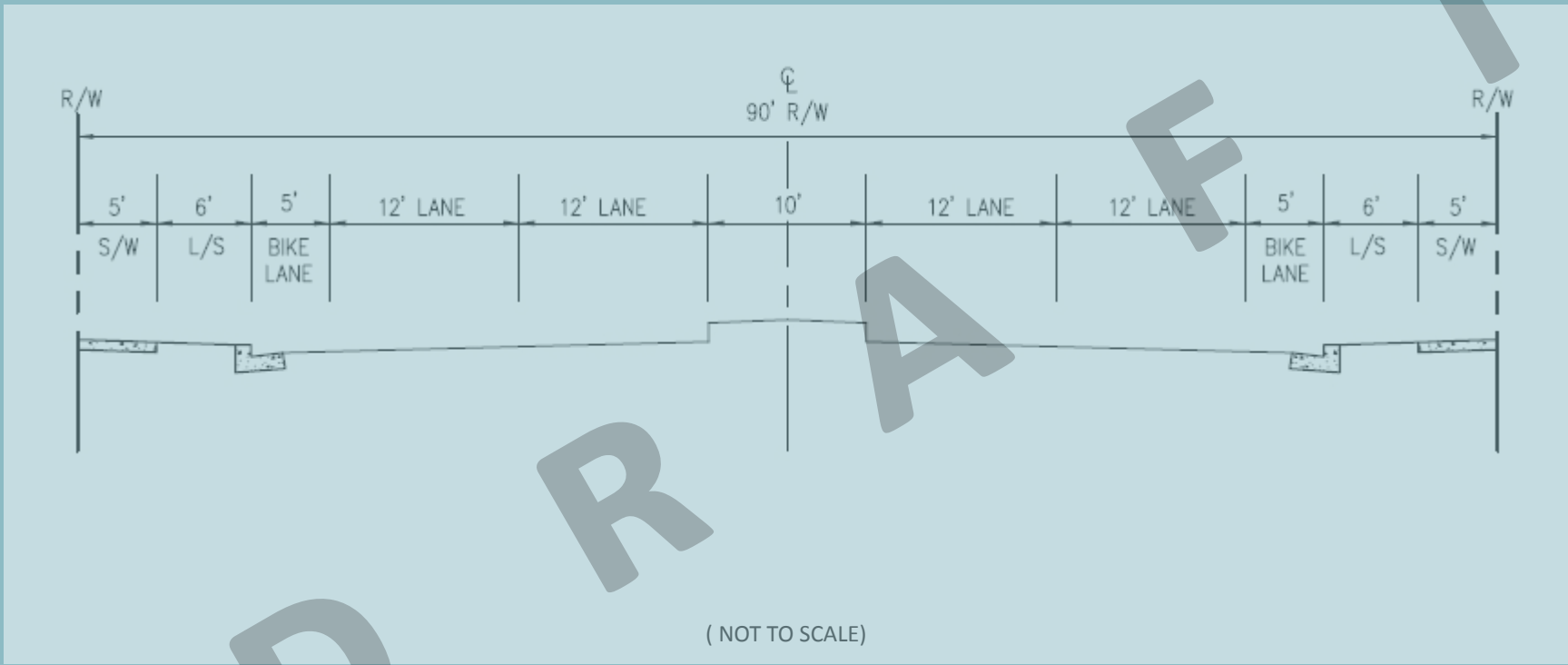

Exhibit 7.10 (a) - Transit Station Entrance Road

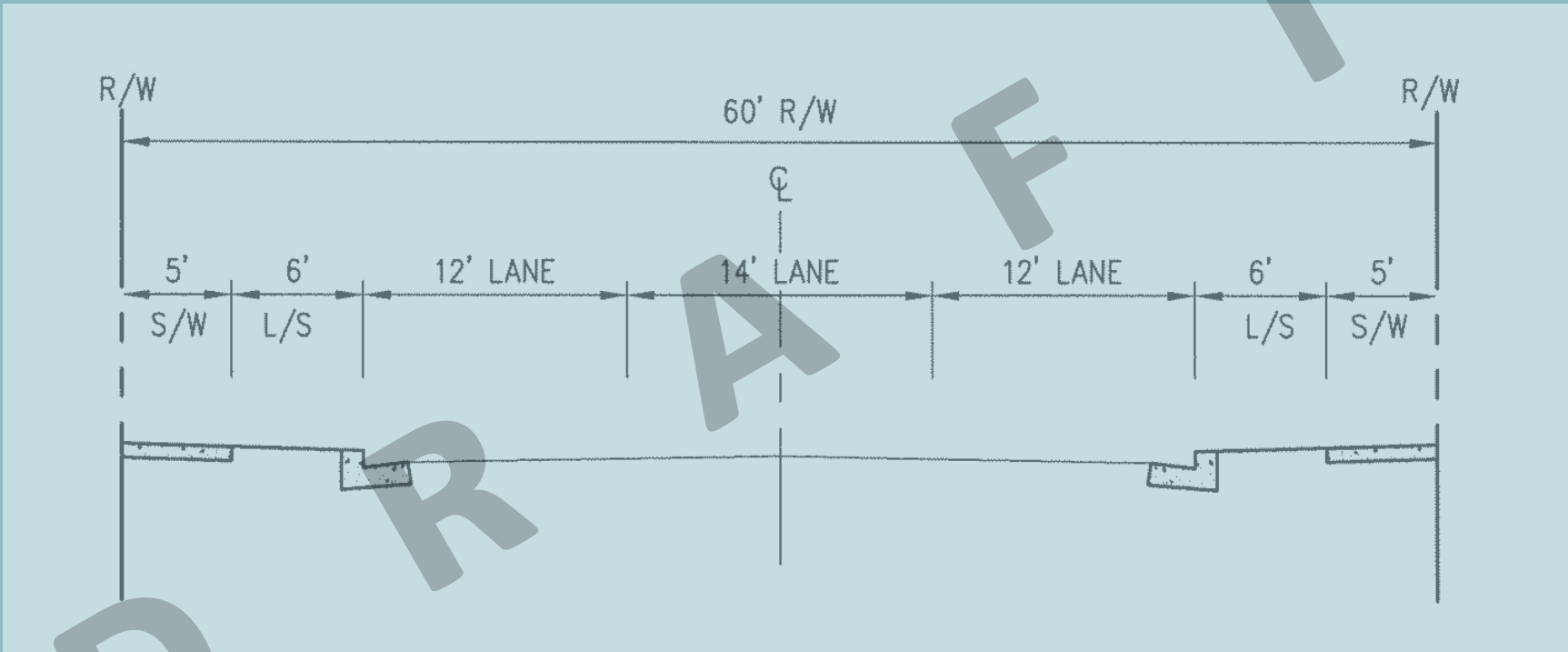

Exhibit 7.10 (b) - Transit Station Road

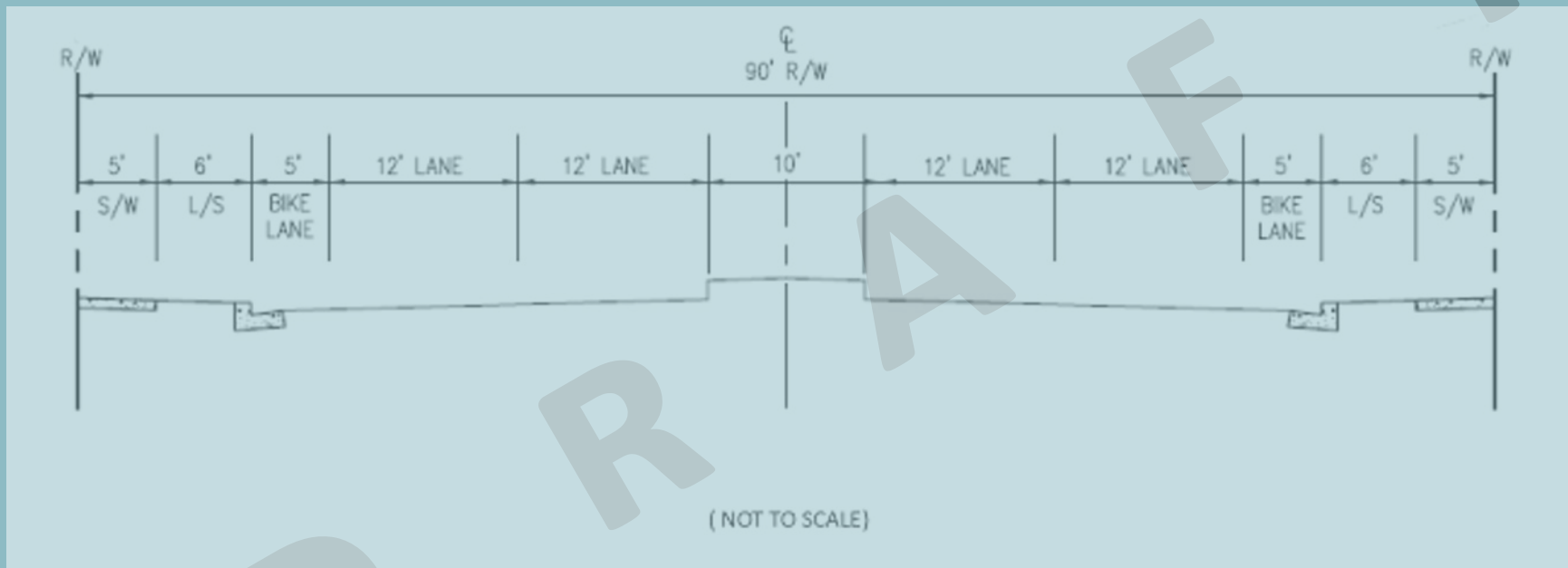

Exhibit 7.11 - Enterprise Drive East (East of Willow Street)

Enterprise Drive East (Exhibit 7.11)

The primary purpose of this street is to move traffic into the Plan area. Enterprise Drive East consists of a 90-foot wide right-of-way. The paved section of the right-of-way consists of a 14-foot vehicular travel lane, a 5-foot bicycle lane and an 8-foot parking bay on either side of the median. The roadway has a vertical curb and gutter, and curb returns have a 20-foot radius.

A 5-foot sidewalk is provided on both sides and separated from the parking areas and roadway by a 6-foot wide landscape strip.

Hickory Street (Exhibit 7.12)

The street will consist of one lane in each direction with parking, landscaping and sidewalks on each side – similar to other streets in this Specific Plan. Direct vehicular lot access on Hickory Street is permitted from residential lots to the street. The roadbed must not lie on top of the easement for the sewer forcemain. The easement for the sewer forcemain may lie within the R.O.W. for Hickory street as either a median, or additional landscape on either side of the roadway.

Exhibit 7.12 shows a possible cross-section, depending on final site conditions.

This street's primary purpose is to move and disperse traffic in the Plan area. This is a higher volume street with a design speed of 35 miles per hour.

Neighborhood Streets (Exhibit 7.13)

Neighborhood streets are not part of the Backbone Circulation Plan. The design of Neighborhood streets shall be as provided in this Specific Plan but the location of each will be determined pursuant to the processing of plans for specific developments within the Specific Plan area.

Neighborhood streets are internal residential streets, the primary purpose of which is to provide access between individual residences and collector streets. These are low-volume streets with a design speed of 25 miles per hour.

Neighborhood streets should consist of a 36-foot wide road section within a 56-foot wide right-of-way. The paved section can accommodate two 10-foot wide travel lanes and on-street parking on both sides in designated parking bays. The roadway had vertical curb and gutter, and curb returns have a 20-foot radius.

A 5-foot sidewalk should be provided on both sides and separated from the parking areas by a 5-foot wide landscaping strip. Direct vehicular lot access is permitted on all neighborhood street from residential lots to the streets.

Tree planting along neighborhood streets shall be designed to encourage pedestrian use, shorten the perception of walking distances and provide shade and seasonal interest.

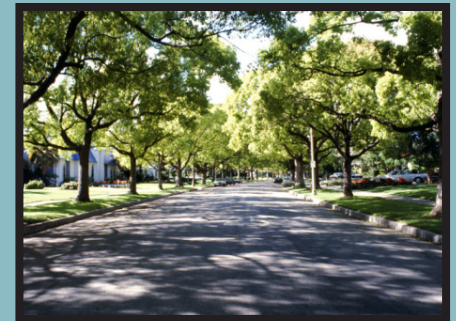
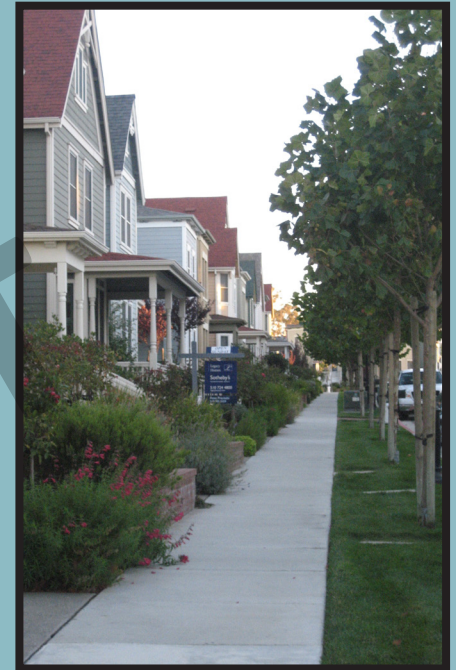

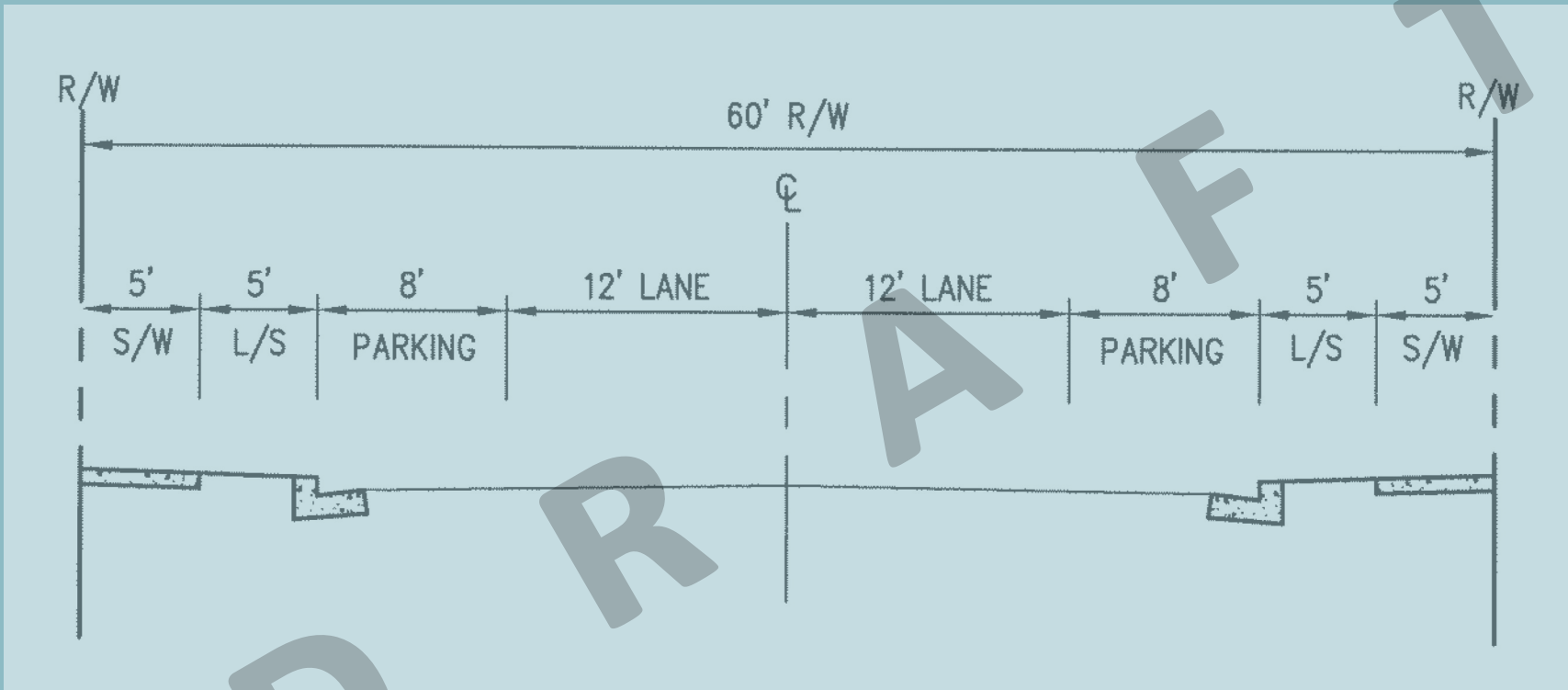

Exhibit 7.12 - Hickory Street

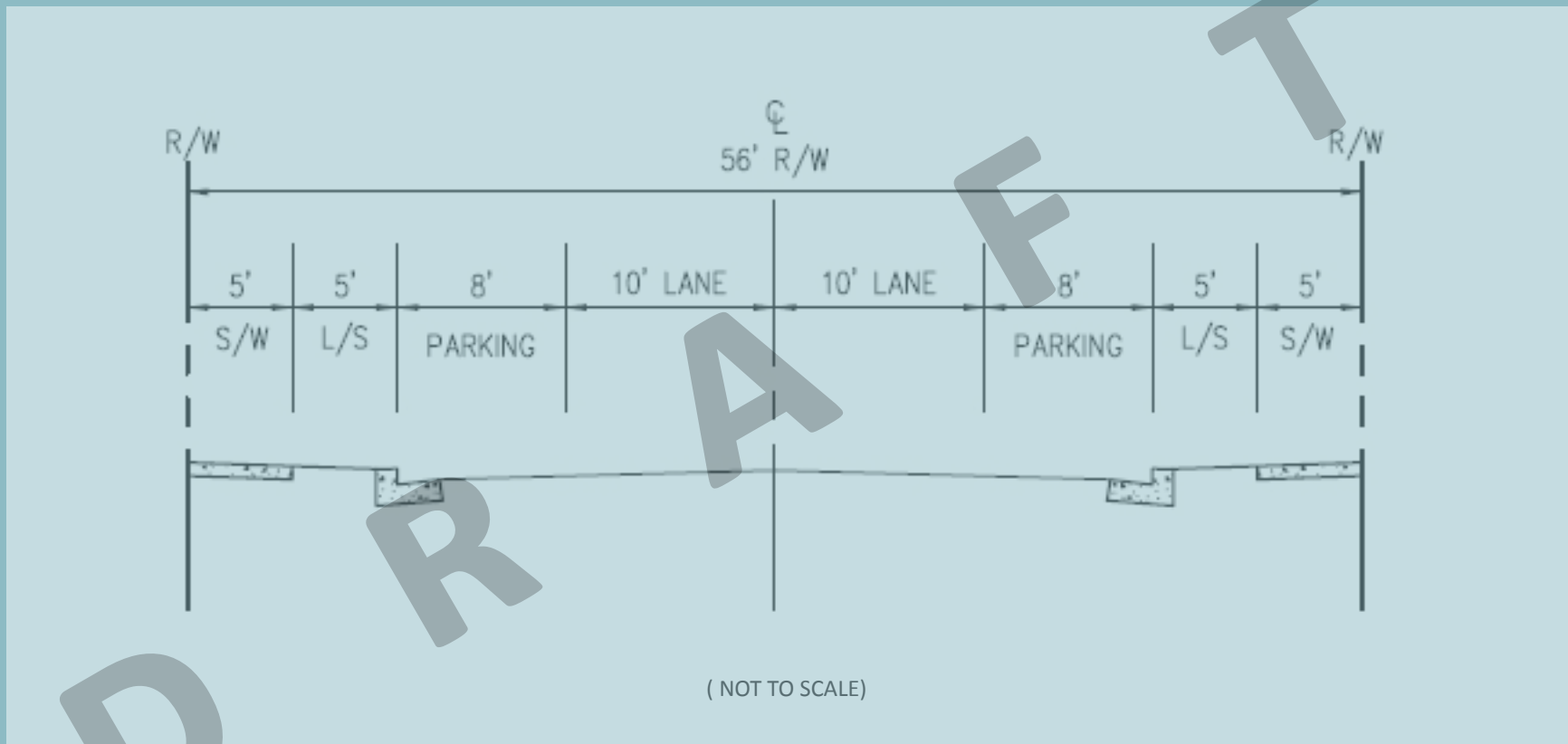

Exhibit 7.13 - Neighborhood Streets Typical - Minor

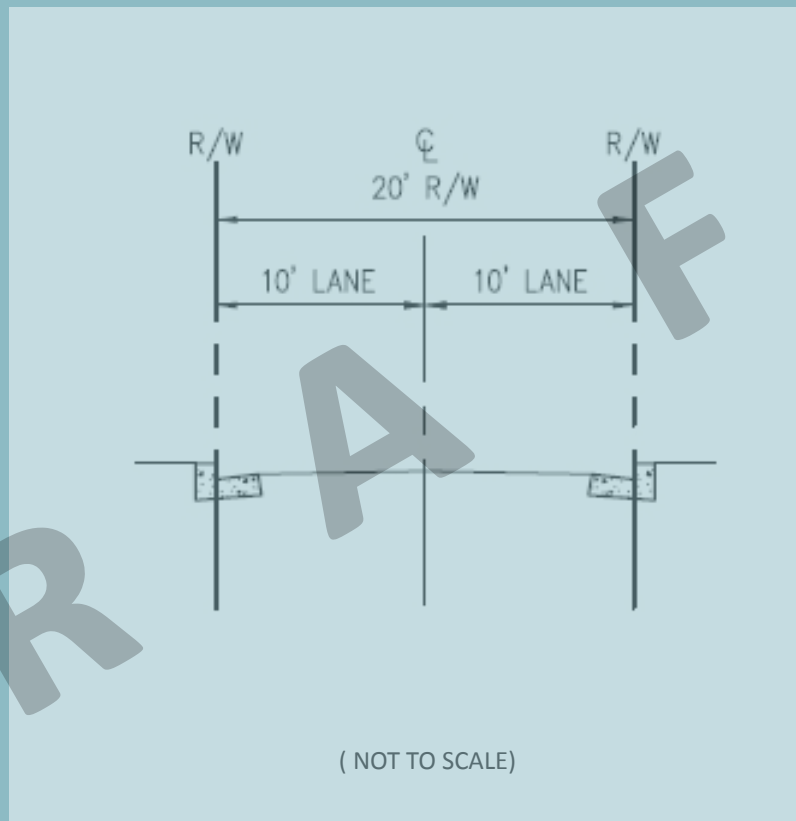

Exhibit 7.14 - Carriageway / Alley

Carriageways (Exhibit 7.14)

Carriageways are generally privately maintained roads associated with residential units where garages are located in the rear of the home and not off the main residential street.

The purpose of the carriage way is to provide service access for garbage trucks and to provide residents vehicular access to their garages. They typically have a paved surface of 20-feet within a 20-foot access easement or right-of-way with the garage doors setback from the street. Direct lot access is permitted on all carriageways/alleys from residential lots to the street. Resident or guest parking is allowed within the carriage way only in designated spaces.

Small accent trees and shrubs are encouraged to be planted in small planting areas within the carriageways. These are typically located between garage doors and building, and soften the edge of the pavement.

Roundabouts (Exhibit 7.15)

A roundabout is a circular intersection with yield control for entering traffic, channelized approaches, and reduced travel speeds in the circular roadway as vehicles must follow a travel path around the center island. Roundabouts have several safety advantages, as they reduce the number of conflict points between vehicles, and between vehicles and bicyclists and pedestrians. A study of US roundabout sites showed a 39% reduction in total crashes and a 76% reduction in injury crashes. The slower travel speeds compared to traditional signalized intersections also reduce the occurrence and severity of collisions. They also have lower average delays than stop-or signal-controlled intersections when serving less than 20,000 vehicles per day. The reduction in delay and idling time also results in less fuel consumption, lowers air pollution and reduces greenhouse gas emissions.

Roundabouts can sometimes present challenges to bicyclists and pedestrian access, especially for those pedestrians with sight impairments. To improve access for all pedestrians, crosswalks may be raised or, for multi-lane roundabouts, signal-controlled.

Enterprise Drive, Hickory Street and Central Avenue may have roundabouts. Actual road sections and right-of-way radius will reflect final engineering plans in the context of specific development projects. One example is shown on Exhibit 7.15. Roundabouts should be enhanced with various materials or plants to soften the hard surfaces, however, clear line of sight is required for both pedestrian and vehicular access.

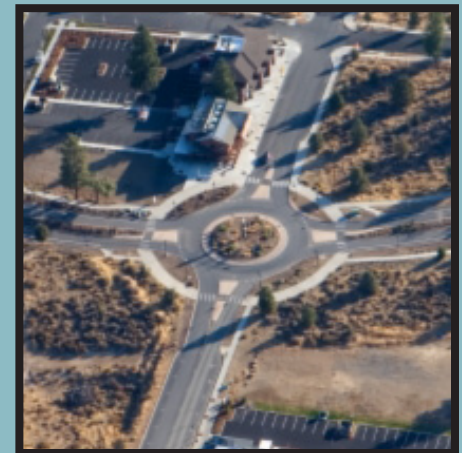

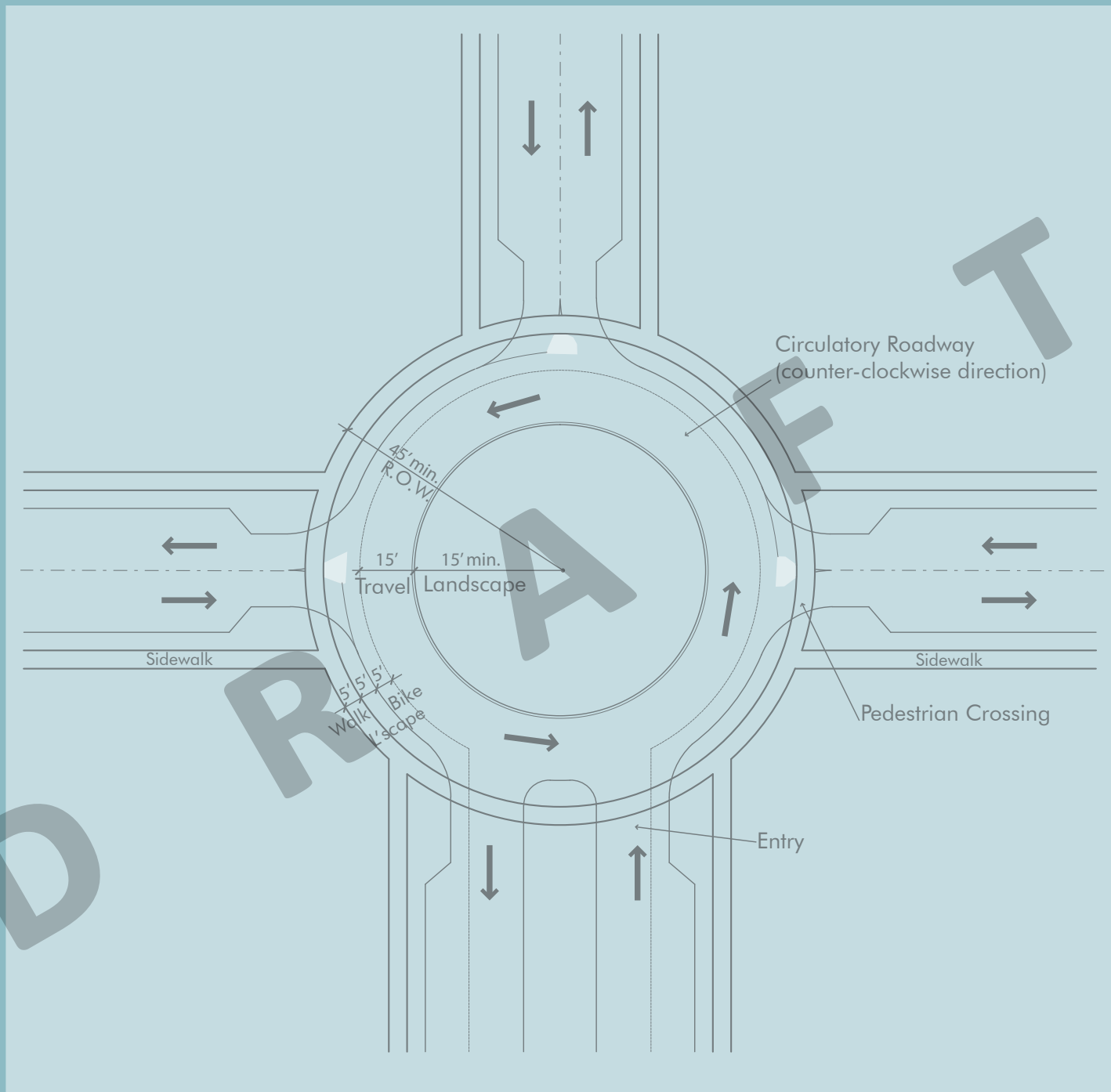

Exhibit 7.15 - Conceptual Roundabout

Cul-de-sac – Hammerhead (Exhibit 7.16)

This type of street is utilized with a private neighborhood street that is no more than 300-feet in length. It is primarily intended to serve as a turn around that uses less land than standard cul-de-sac. The hammerhead has a paved driving surface of 75-feet long by 20-feet wide. The curb radius is 20-feet and no parking is permitted, signs will be posted. No sidewalks are required. Direct lot access is permitted on cul-de-sacs from residential lots to the street.

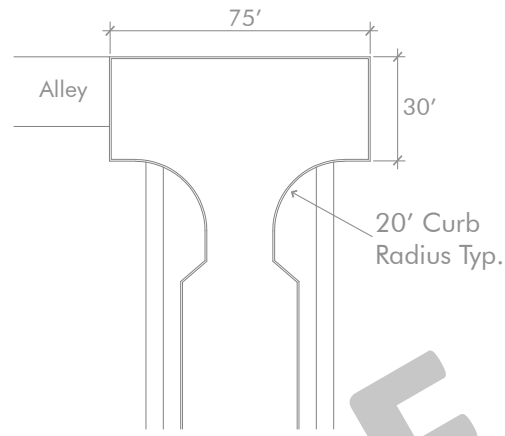

Exhibit 7.16- Cul de Sac - Hammerhead (Private Road)

Cul-de-sac – Traditional (Exhibit 7.17)

This type of cul-de-sac is utilized with a neighborhood street that is no more than 450-feet in length. The bulb of the cul-de-sac is 95-feet in diameter. The paved driving surface is 75-feet in diameter. The curb radius to the connecting neighborhood street is 20-feet. A 5-foot wide sidewalk that is separated by a 5-foot wide planting strip is provided. Direct lot access is permitted on cul-de-sacs from residential lots to the street

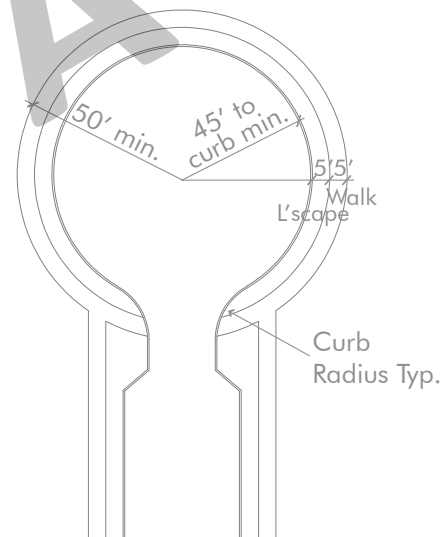
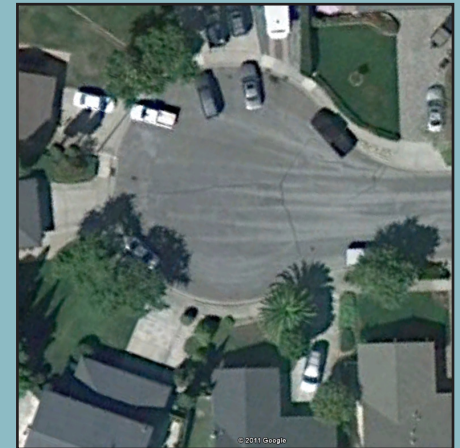

Exhibit 7.17 - Cul de Sac - Traditional



7.8 STREET STANDARDS CHART

On this page is Table 7.1 - a summation of the street design standards presented earlier in this chapter.

Table 7.1 Street Standards									
Street Names	R.O.W	Pavement Width	No. of Lanes	Median	Sidewalk Within R.O.W.	Landscape Strip within R.O.W.	On-Street Parking Allowance	On-Street Bike Lanes	Direct Lot Access
Willow Street	80'-88'	64'	2	8'	5' both sides for two conditions, 5' one side for third condition	6'-8' both sides for two conditions, 3'-8' both sides for third condition	8' both sides, all conditions	5' both sides, all conditions	Direct lot access from single family detached lots is not allowed along Willow, however, curb cuts and all means of ingress and egress is allowed for all other uses
Enterprise Dr., (West)	90'	68'	2 for one condition, 4 on second condition	10' and 12'	5' both sides, all conditions	6'-8' both sides	8' both sides one condition, none on second condition	5' both sides, all conditions	On Enterprise, specifically between Willow Street and Hickory Street, direct lot access from single family detached lots is not allowed, however, curb cut and all means of ingress and egress are allowed for all other cases
Central Avenue	80'	60'	2	n/a	5' both sides	5' both sides	8' both sides	n/a	Yes
Transit Station Entrance Road	90'	68'	4	10'	5' both sides	6' both sides	n/a	5' both sides	Yes
Transit Station Road	86'	64'	2	14' striped only	5' both sides	6' both sides	8' both sides	5' both sides	Yes
Enterprise Dr., (East)	90'	68'	2	12'	5' both sides	6' both sides	8' both sides	5' both sides	Yes
Hickory Street	80'	36'-60'	2	N/A	5' both sides, all conditions	5' both sides, all conditions	8' both sides, all conditions	n/a	Yes
Neighborhood Streets - typical will vary depending on site conditions	56'	36'	2	n/a	5' both sides	5' both sides	8' both sides	n/a	Yes
Carriageways	20'	20'	2	n/a	n/a	n/a	n/a	n/a	Yes

Note: Landscape strips may be substituted with tree wells and the sidewalk widened adjacent to mixed-use, commercial, retail and podium buildings.

D
R
A
F
T

